

NAME, ARTICLE NUMBER AND E-NUMBER

Name, article number and email number

Name	Item number	E-number (sv)
10 Output Module	A-FU002410OP01	52 135 90

Name	Item number	E-number (sv)
10 Output Module Mini	MI01FU002410OP01	52 136 22
<i>[sv] 8 Output module PTC CTRL</i>	<i>[sv] A-FU122408OP03LM01</i>	52 137 79

TECHNICAL SPECIFICATIONS 10 OUTPUT MODULE

10 Output module is a protection module with 10 fully protected outputs, of which seven are prioritized and three are non-prioritized. The card is mounted

on sheet metal in battery backup or via nylon fasteners. When ordering, check that the card fits the battery backup card to be installed in.

INSTALLATION AND COMMISSIONING

Instruction No: 350-160

INSTALLATION IN BATTERY BACKUP

Mount the card in any card slot in the enclosure, leave plenty of room for cables.

Check that the card fits with the device before mounting. Even if the card fits mechanically, it is not guaranteed to be supported electrically. It is the responsibility of the installer that the card is compatible with battery backup.



Note

Install and connect option cards before commissioning battery backup.

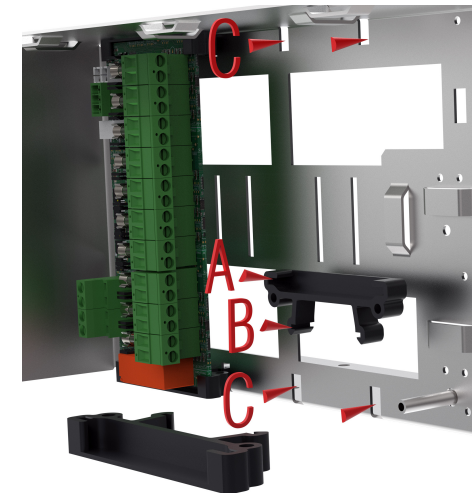

Cards are mounted in battery backup

Letter	Explanation
A	The card must sit in the plastic spacers with the connections on the card facing up.
B	Hooks to attach to the plate (C).
C	Snap on plastic spacers.

Installation directly on sheet metal in battery backup

If the battery backup lacks fasteners for plastic spacers, the card can be screwed directly into the plate.

The plate has flaps that must be folded down and the card must be screwed into these.

Plastic spacers must be placed between the card and the plate to avoid a short circuit in the card.

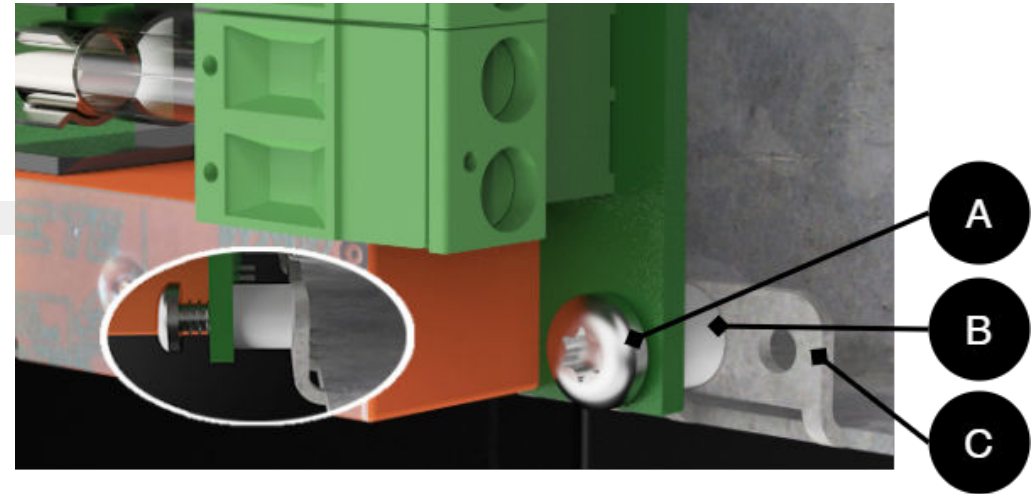

Cards are mounted in battery backup

Letter	Explanation
A	Torx, M2.9 x 9.5 mm.
B	Plastic spacer, M3 x 4 mm.
C	Tab that folds in before the card is screwed on.



Note

Install and connect option cards before commissioning battery backup.

CARD DESCRIPTION 5 OUTPUT MODULE

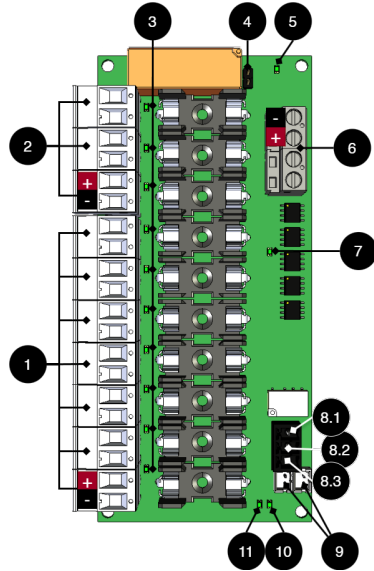

Important

From the factory, all ten outputs are prioritized, (4 are jumpered).

Circuit Board Overview - 10 Output module

No .	On circuit board	Explanation
1	P1:1-14	Priority load outputs -/+. (Odd numbers = minus, even numbers = plus). A prioritized load output always has voltage.
2	P1:15-20	Unprioritized load outputs -/+. (Odd numbers = minus, even numbers = plus). In battery operation, the load is released if 4 is not bridged. If the jumper is on 4, the load outputs are prioritized.
3	D1-D10	Green indicator diode, lights up with a solid green light when the fuse is ok.
4	JU1	Jumper to control three outputs. Factory setting is mounted jumper = all 10 outputs are activated. Without a jumper, only priority outputs (1) P1:1-14 are activated. If the jumper is removed, the outputs, 2, are controlled from 9.
5	D10	Green indicator diode, lights up with a solid green light when all outputs are activated.
6	P2:1-4	Incoming voltage from motherboard, 24 V. (1,3=+, 2,4=-).
7	D17	Indicator diode lights up orange if priority outputs are activated.
8.1	P1:3	Alarm output, NO.
8.2	P1:2	Alarm Output, Com.
8.3	P1:1	Alarm Exit, NC.
9	J11-J12	Connection of alarms to motherboard and/or bridging of alarms from another board. Use any connection to connect alarm to motherboard. If the jumper, 4, is removed, the outputs, 2, are controlled with the coupling, see connection to the board.
10	D29	Indicator diode that lights up with a solid green light when all fuses are ok.
11	D30	Indicator diode that lights up with a solid red light if any fuse is faulty.

Use the supplied cable

Use the cable that comes with the box to connect the card.

CONNECT 10 OUTPUT MODULE TO MOTHERBOARD: CEO3 V2.1

Connect the card as shown in the picture.

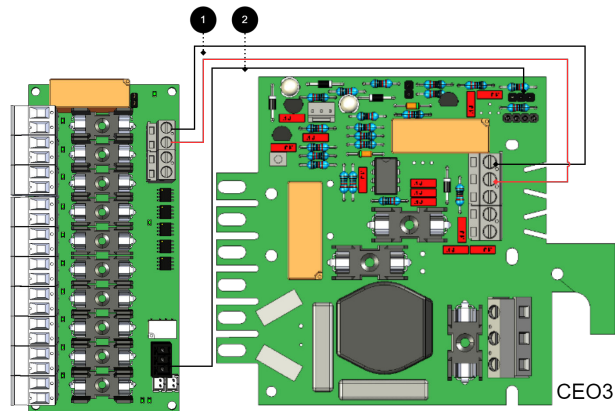

+ and - from load on motherboard are connected to + and - on the option board.

Communication is connected between terminals as the solid line shows.

Connecting the power supply

Connect power (24 V) from the battery backup's load output to the card's 24 V input.

Connection of load

Connect load wiring to P1:1-14 on fuse module for priority load. P1:15-20 for non-priority cargo. (Cards supplied with T2A fuses).



Caution

Maximum load is 5 A per load output, and the card's total load must not exceed 16 A.

Connections from battery backup to fuse board

No	Connections	10 Output module	Motherboard
1	Power supply connection:	IN 12 V / 24 V	Load output 1
2	Alarm output: connected between NO and Com	P3: 1-3 (2-3)	JU3 Connects between the middle pin and an outer pin.
-	Bridging alarms to the card is not possible as the card has no alarm input.	-	-

Connect 10 Output module to motherboard: CEO3 v5

Connect the card as shown in the picture.

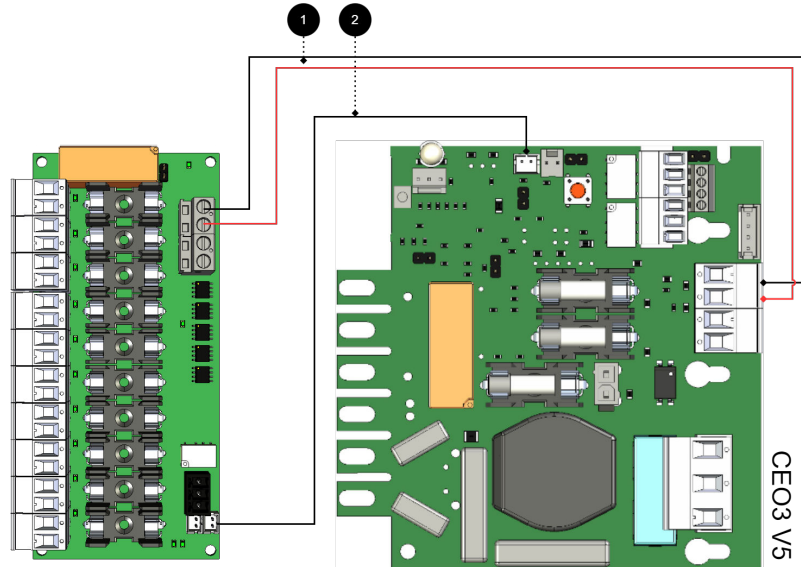

+ and - from load on motherboard are connected to + and - on the option board.

Communication is connected between terminals as the solid line shows.

Connecting the power supply

Connect power (24 V) from the battery backup's load output to the card's 24 V input.

Connection of load

Connect load wiring to P1:1-14 on fuse module for priority load. P1:15-20 for non-priority cargo. (Cards supplied with T2A fuses).



Caution

Maximum load is 5 A per load output, and the card's total load must not exceed 16 A.

Connections from battery backup to fuse board

No	Connections	10 Output module	Motherboard
1	Power supply connection:	IN 12 V / 24 V	Load output 2
2	Bridging alarm to motherboard:	J11	J27
	Bridging of alarms to another 10 Output module	J11 or J12	J11 or J12

Connect 10 Output module to motherboard: NEO3

Connect the card as shown in the picture.

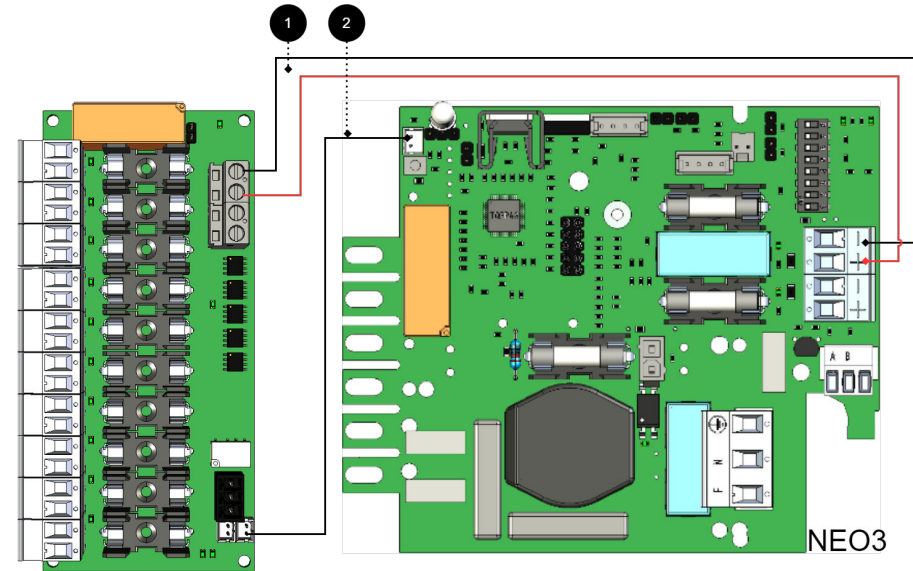

+ and - from load on motherboard are connected to + and - on the option board.

Communication is connected between terminals as the solid line shows.

Connections from battery backup to fuse board

No	Connections	10 Output module	Motherboard
1	Power supply connection:	IN 12 V / 24 V	Load output 2
2	Bridging alarm to motherboard:	J11	J5
	Bridging of alarms to/from additional option cards	J12	

Connect 10 Output module for motherboard: PRO1 5 A and 10 A

Connect the card as shown in the picture.

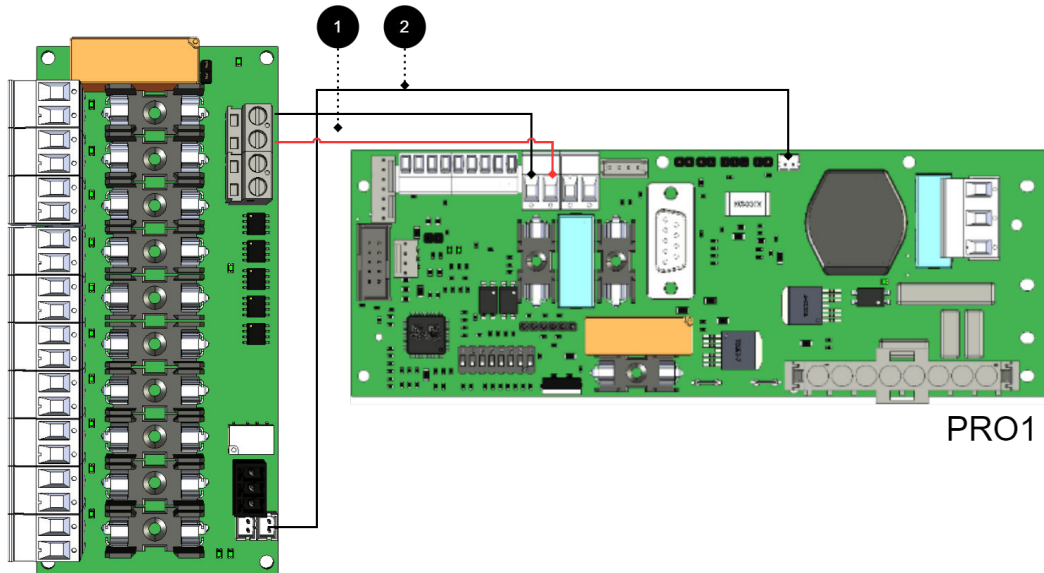

+ and - from load on motherboard are connected to + and - on the option card.

Communication is connected between terminals as the solid line shows.



Important

Early versions of PRO1 and PRO2 may lack white terminal (JST), which lacks a JST contact, then the alarm is connected via relay switching. P3:1-3. [If the card lacks a white \(JST\) contact or if the alarm is to be given via relay switching \[7\]](#)

Connect 10 Output module for motherboards: PRO2 v3 15 A and 25 A

Connect the card as shown in the picture.

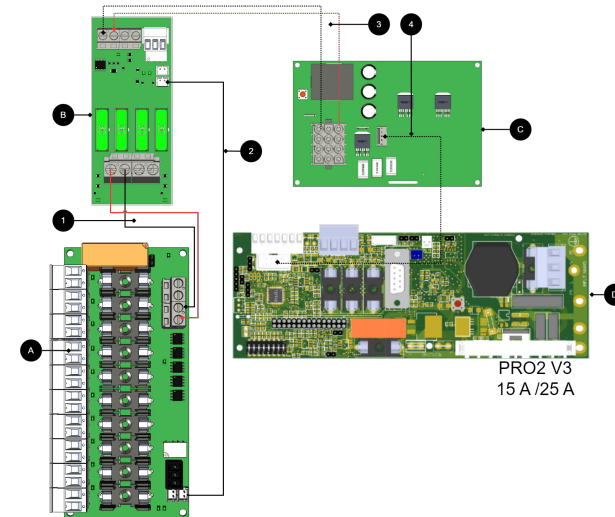

+ and - from load on motherboard are connected to + and - on the option board.

Communication is connected between terminals as the solid line shows.



Important

Early versions of PRO1 and PRO2 may lack white terminal (JST), which lacks a JST contact, then the alarm is connected via relay switching. P3:1-3. [If the card lacks a white \(JST\) contact or if the alarm is to be given via relay switching \[7\]](#)

Connections from battery backup to fuse board

No .	Connections	10 Output module	Motherboard
1	Power supply connection:	IN 12 V / 24 V	Load output 1
2	Bridging alarm to motherboard:	J11	J13
	Bridging alarms to/from additional option cards:	J12	-

Connections 15 A and 25 A units

No/letter	On circuit board	Explanation
A	10 Output modules	Optional card.
B	2 Output module	Card for connection of load and power supply to 10 Output module.
C	Effect card	Available in 15 A and 25 A units.
D	PRO2 v3	Motherboard in battery backup.

No/letter	On circuit board	Explanation
1	P2:3-4	Connect power supply from 2 Output module (B) to 10 Output Module (A)
2	J11	Alarm output, connects to load card.
3,4	-	Internal power supply between cards.

Connections from battery backup to fuse board

No	Connections	10 Output module	Motherboard
1	Power supply connection:	IN 12 V / 24 V	Load output 1
2	Alarm output:	P3:1-3	J13

If the card lacks a white (JST) contact or if the alarm is to be given via relay switching

Connect the card as shown in the picture.

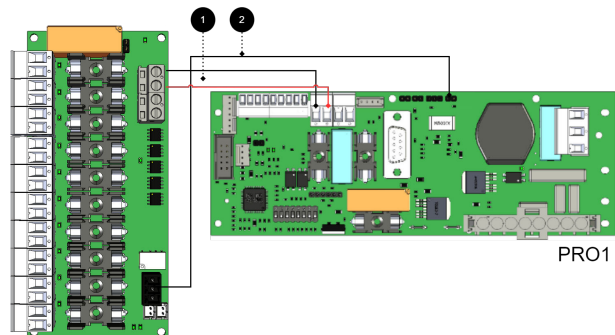

Older cards¹ which lacks a JST contact, then the alarm is connected via relay switching. P3:1-3

¹Early versions of PRO1 and PRO2 may lack white terminal (JST).

CONNECTION OF ANOTHER 10 OUTPUT MODULE

Connecting additional option cards to the motherboard

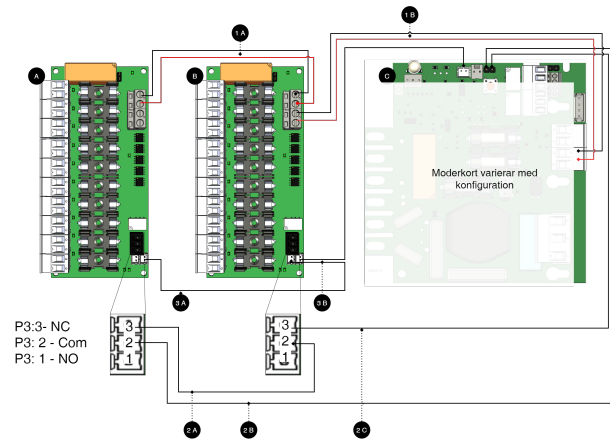

Note

For alarm connection use 2A and 2B for connection of newer devices (after approx. 2018). For older devices (before approx. 2018) use 3A-3C.

Connection of additional option cards

Letter / No	Explanation	On the card
A	10 Output modules.	-
B	10 output modules.	-
C	Motherboard, may vary with configuration.	-
1 A	Power supply from 1B.	IN 24 V
1 B	Power supply from C (motherboard).	IN 24 V
2 A	Bridging of alarms to card B.	J12
2 B	Connection of alarm on C (motherboard) from board A.	See table below.
2C	Connection of alarm on C (motherboard) from board B.	See table below.
3 A	Alarm output switches on C (motherboard).	P3:1-3
3 B	Alarm output is connected to C (motherboard).	P3:1-3

Alarms from optional cards are connected on terminal block (on motherboard)

Motherboard	Terminal as an alarm from an optional card must be connected (on motherboard)
CEO3 v5	J27
NEO3	J5
PRO1	J13
PRO2 v3	J1
PRO3	J5

10 OUTPUT MODULE IN DELIVERED IN HOUSING

The card is also available mounted in a lockable enclosure.

INSTALLATION OF ENCLOSURE B3

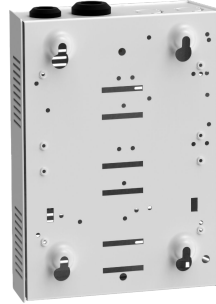

The B3 enclosure has four holes for wall mounting.

Cable entries are on the top side.

TECHNICAL DATA - 10 OUTPUT MODULE

Info	Explanation
Short name:	10 Output module
Product description	10 Output module is a hedging module with 10 fully secured outputs, of which seven are prioritized and three are non-prioritized.
The product fits in	Battery backups with motherboards: PRO1, PRO2, PRO2 V3, PRO3 and NEO3.
Measure	30 x 55 x 120 mm
Own consumption	70 mA
Tension	24 V
Fuses	F10A
Indication	Yes, LED on circuit board

Outputs

Info	Explanation
Alarm outputs, number	1
Alarm on alternating relay? (Yes No)	Yes, sum alarm in case of fuse fault
Alarm output protocol (communication protocol)	-

Info	Explanation
Load outputs, number	10
Voltage at load output	27.3 V DC
Voltage limit, upper, on load output	27.9 V DC
Voltage limit, lower, on load output. For battery operation and disconnected mains voltage.	20 V DC
Priority (always voltage) load outputs (Yes / No)	Yes
Maximum load, per output	10 A
Maximum load, total, (must not be exceeded).	16 A
Load output plus (+) secured? (Yes No)	Yes
Load output minus (-) secured (Yes / No)	No
Fuses on output	Yes, see table: Fuses.
Connection to buzzer? (Yes No)	No

Manufactured in Milleteknik's factory in Partille, Sweden.

This translation is not verified and should be cross referenced with the swedish original before use.

ABOUT TRANSLATION OF THIS DOCUMENT

User manual and other documents are in the original language in Swedish.
Other languages may be machine translated and/or not reviewed, errors may occur.

ENCLOSURES - TECHNICAL DATA S

Info	Explanation
Name	B3
Enclosure class	IP 20
Measure	Height: 202, width: 148, depth: 65 mm
Mounting	Wall
Ambient temperature	+ 5 ° C - + 40 ° C. For best battery life: + 15 ° C to + 25 ° C.

Info	Explanation
Environment	Environmental class 1, indoors. 20% ~ 90% relative humidity
Material	Powder coated sheet
Color	White
Cable entries, number	2
Place for fan	No

ADDRESS AND CONTACT DETAILS

Milleteknik AB
Ögärdesvägen 8 B
S-433 30 Partille
Sweden
+46 31 340 02 30
info@milleteknik.se
www.milleteknik.com